

XO CNT SGT

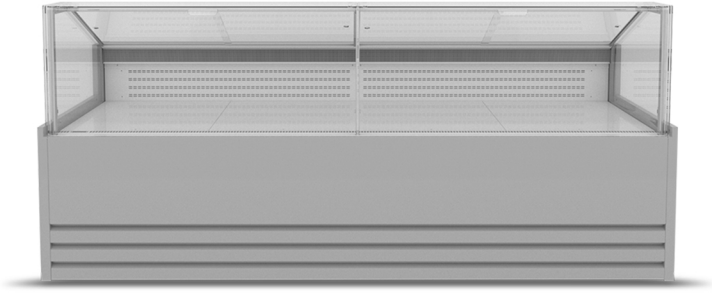

Technology

Plug-in (Air Cooled or Water Loop)

Climate and Product Class

3M1

Product Temperatures

M1 :-1C- +5C / M2: -1C-+7C

Refrigerant

R290

Defrost

Off cycle

Illumination

LED Lights

Side Panels

Panoramic / Blind

Power supply

230V / 3 Ph / 50 Hz

Inner Colours



Outer Colours

RAL Optional

Energy Class

Code	Length	Class
Xo Cnt Sgt 2500	2500	
Xo Cnt Sgt 1875	1875	
Xo Cnt Sgt 1250	1250	
Xo Cnt Sgt 937	937	

Code	Dimensions mm	Depth mm	Volume Lt	TDA m ²	TEC kwh/24h	EEI / Eco Label
Xo Cnt Sgt 2500	2500 x 1145 x 1130 mm	1145	349	2,79	10,69	26,1 % -C
Xo Cnt Sgt 1875	1975 x 1145 x 1130 mm	1145	262	2,09	8,34	25 % -C
Xo Cnt Sgt 1250	1350 x 1145 x 1130 mm	1145	174	1,39	5,67	21,9 % -C
Xo Cnt Sgt 937	1037 x 1145 x 1130 mm	1145	130	1,04	4,5	20,4 % -C

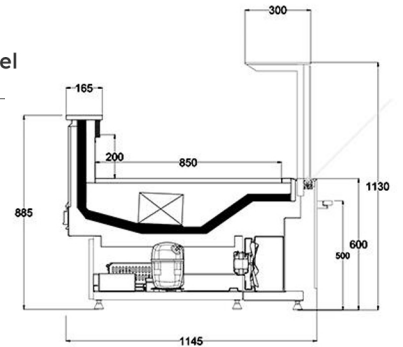

Options:



LED Shelf Lighting



Bumper



Tekso IoT Temperature Monitoring System