

XO CNT SHELF

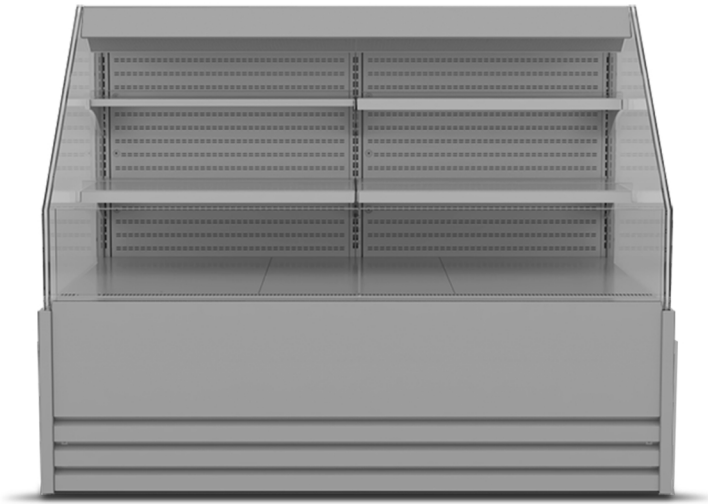

Technology
 Plug-in (Air Cooled or Water Loop)
Climate and Product Class
 3M1
Product Temperatures
 M1 :-1C- +5C
Refrigerant
 R290
Defrost
 Off cycle

Illumination
 LED Lights
Side Panels
 Panoramic / Blind
Power supply
 230V / 3 Ph / 50 Hz
Inner Colours

Outer Colours
 RAL Optional

Energy Class

Code	Length	Class
Xo Cnt Shelf 2500	2500	
Xo Cnt Shelf 1875	1875	
Xo Cnt Shelf 1250	1250	
Xo Cnt Shelf 937	937	

Code	Dimensions mm	Depth mm	Volume Lt	TDA m ²	TEC kwh/24h	EEI / Eco Ial
Xo Cnt Shelf 250	2500 x 1145 x 1130 mm	1145	980	2,82	14,5	33,2 % -C
Xo Cnt Shelf 1875	1875 x 1145 x 1130 mm	1145	736	2,11	11,9	33,2% -C
Xo Cnt Shelf 1250	1250 x 1145 x 1130 mm	1145	491	1,41	8,26	29,8 % -C
Xo Cnt Shelf 937	937 x 1145 x 1130 mm	1145	367	1,05	8,01	33,9 % - C

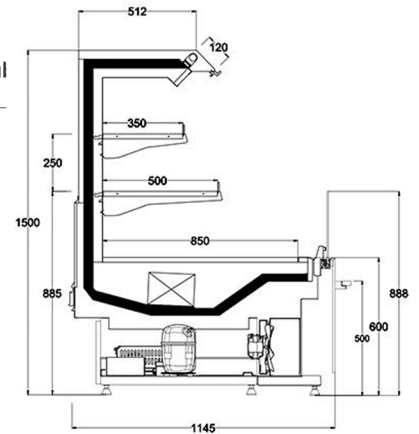

Options:



LED Shelf Lighting



Bumper



Canopy



Tekso IoT Temperature Monitoring System